



# **INSTALLATION AND USER MANUAL**

Thank you for choosing Aqua inverter heat pump

This manual provides you necessary information for optimal use and maintenance, please read it carefully and keep it for subsequent use.

t



# Summary

## **For users ..... P.1-P.6**

>	1. General information.....	- 1 -
	1.1. Contents.....	- 1 -
	1.2. Operating conditions and range .....	- 1 -
	1.3. Advantages of different modes.....	- 1 -
	1.4. Kind reminder.....	- 2 -
>	2. Operations .....	- 4 -
	2.1. Notice before using .....	- 4 -
	2.2. Operation instructions .....	- 4 -
	2.3. Daily maintenance and winterizing .....	- 5 -
>	3. Technical specification.....	- 6 -

## **For installers and professionals ..... P.7-P.17**

>	1. Transportation.....	- 7 -
>	2. Installation and maintenance .....	- 7 -
	2.1. Notice before installation .....	- 7 -
	2.2. Installation instructions .....	- 8 -
	2.3. Trial after installation .....	- 11 -
	2.4. Maintenance and winterizing .....	- 11 -
>	3. Trouble shooting for common faults.....	- 12 -
>	4. Failure code.....	- 13 -
>	Appendix 1: Heating priority wiring diagram .....	-14-

## > 1. General information:

### 1.1. Contents:

After unpacking, please check if you have all the following components.

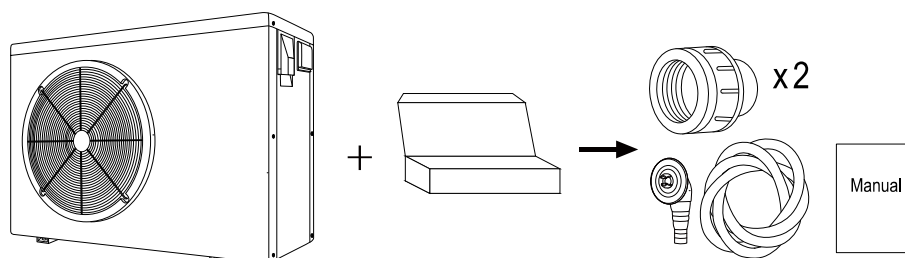

### 1.2. Operating conditions and range:

Items		Range
Operating range	Air temp	-7°C ~ 43°C
	Water temp	0°C ~ 35°C
Temp. setting	heating	18°C-35°C

*The heat pump will have ideal performance in the operation range Air 15°C~25°C*

### 1.3. Advantages of different modes:

The heat pump has two modes: Smart and Silence. They have different advantages under different conditions

Mode	Recommendation	Advantages
<b>Smart</b> <input type="checkbox"/>	As standard	Heating capacity: 20% to 100% capacity Intelligent optimization Fast heating
<b>Silence</b> <input type="checkbox"/>	Use at night	Heating capacity: 20% to 80% capacity Sound level: 3dB (A) lower than Smart mode.

1.4. Kind reminder:

 This heat pump has Power-off memory function. When the power is recovered, the heat pump will restart automatically.

1.4.1. The heat pump can only be used to heat the pool water. It can NEVER be used to heat other flammable or turbid liquid.

1.4.2. Don't lift the water union when moving the heat pump since the titanium heat exchanger inside the heat pump will be damaged.

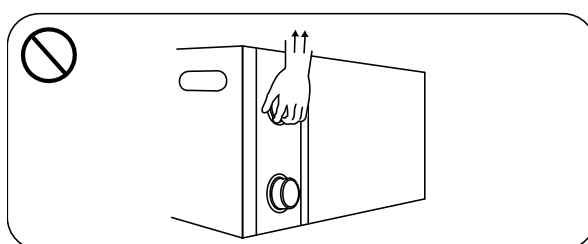

1.4.3. Don't put obstacles before the air inlet and outlet of the heat pump.

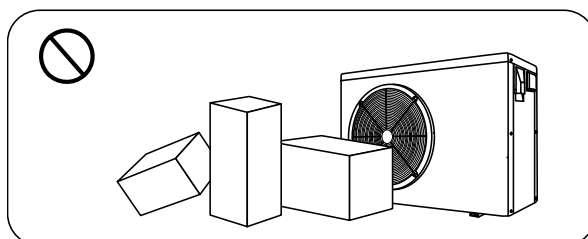

1.4.4. Don't put anything into inlet or outlet, or the efficiency of the heat pump will be reduced or even stopped.

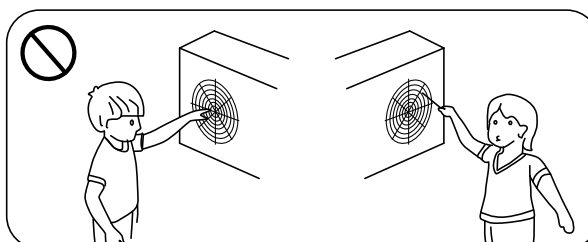

1.4.5. Don't use or store combustible gas or liquid such as thinners, paint and fuel to avoid fire.

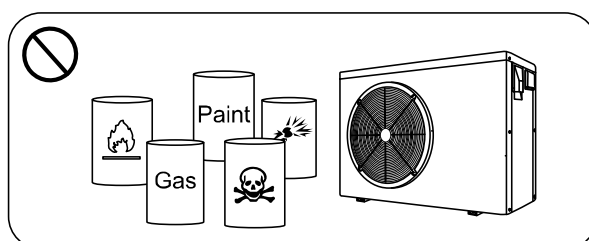

1.4.6. If any abnormal circumstances occurred, e.g.: abnormal noises, smells, smokes and leakage of electricity, switch off the main power immediately and contact your local dealer. Don't try to repair the heat pump by yourselves.

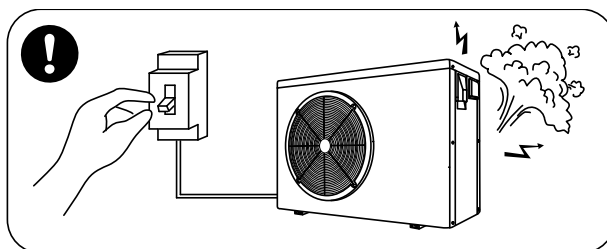

1.4.7. The main power switch should be out of the reach of Children.

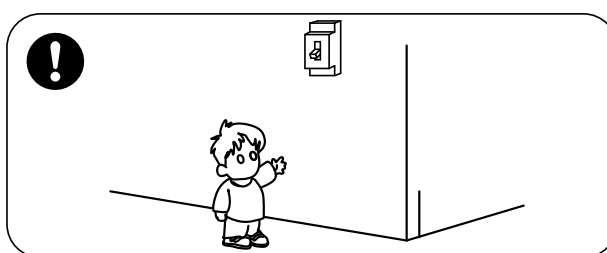

1.4.8. Please cut off the power in the lightning storm weather.

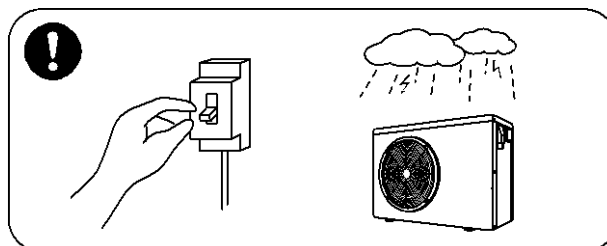

1.4.9. Please note that following codes are not failure.

	Codes
Out of the operating range	E6
No water	E3
Insufficient water flow or pump blocked	E6
Power abnormal	E5
Defrosting	☀️ ◻️ heating light twinkling

## > 2. Operations

### 2.1. Notice before using

- ① The user is advised to start the water pump before the heat pump, and turn off the heat pump before the water pump for long life circle.
- ② Check firstly for any water leakage of piping connection, then power on, press the ON/OFF button of the heat pump, and set suitable temperature.

### 2.2. Operation instructions

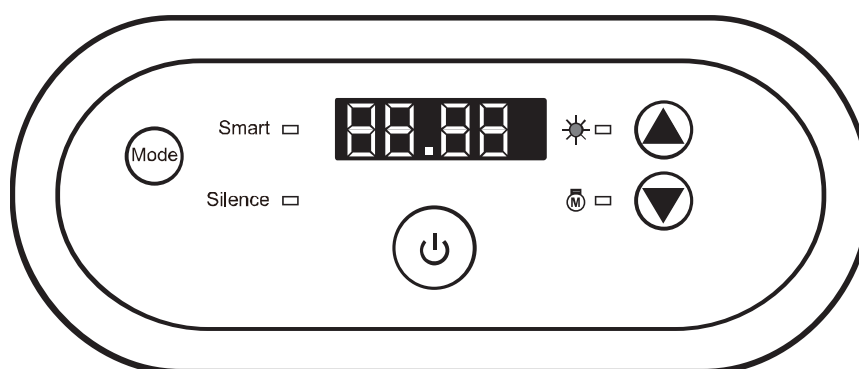





Symbol	Designation	Operation
	Power ON/OFF	Press to power on or off the heat pump
	Mode	Press to select Smart/Silence mode
	Up/ Down	Press to set desired water temperature



#### Note:

- ① You may set the desired water temperature from 18 to 35°C.
- ② The on the right shows the inlet water temperature. The on the left shows the set temperature by pressing at the same time.
- ③ After you turn on the heat pump, the fan will start to run in 3 minutes. In another 30 seconds, the compressor will start to run.
- ④ During heating, the will be light.

### 2.2.1. Mode selections

- ① Smart  will be light as standard when you turn on the heat pump.
- ② Press the  button to enter the Silence mode, the Silence  will be light.  
Press the  button again to exit and enter the SMART mode.

### 2.2.2. Compulsory defrosting

- ① When the heat pump is heating and the compressor is working continuously for 10 minutes, press both “” and “” buttons for 5 seconds to start compulsory defrosting. (Note: the interval between compulsory defrosting should be more than 30 minutes.)
- ② The heating light will be twinkling when heat pump is in compulsory or auto defrosting.
- ③ The running process and ending of compulsory defrosting are the same as auto-defrosting.

## 2.3. Daily maintenance and winterizing

### 2.3.1. Daily Maintenance

 Please don't forget to cut off power supply of the heat pump

- ① Please clean the evaporator with household detergents or clean water, NEVER use gasoline, thinners or any similar fuel.
- ② Check bolts, cables and connections regularly.

### 2.3.2. Winterizing

In winter season when you don't swim, please cut off power supply and drain water out of the heat pump. When using the heat pump under 0°C, make sure that the water pump is always running.

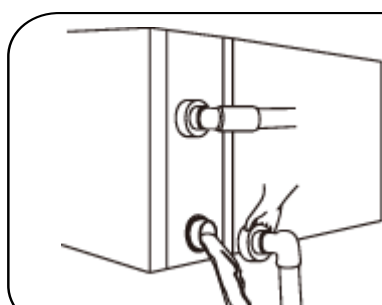

 **Important:**

Unscrew the water union of inlet pipe to let the water flow out.

When the water in machine freezes in winter season, the titanium heat exchanger may be damaged.



### > 3. Technical specification

Model	34-180139	34-180140
Advised pool volume (m <sup>3</sup> )	25-50	30-60
Working air temp (°C)	-7~43	
<b>Performance Condition: Air 26°C, Water 26°C, Humidity 80%</b>		
Heating capacity (kW)	11.3~2.8	13.3~3.4
Heating capacity (kW) in silence mode	9.0~2.8	10.4~3.4
C.O.P	15.1~6.5	15.0~6.4
C.O.P in silence mode	15.1~7.5	15.0~7.4
<b>Performance Condition: Air 15°C, Water 26°C, Humidity 70%</b>		
Heating capacity (kW)	7.3~1.9	9.4~2.3
Heating capacity (kW) in silence mode	5.8~1.9	7.4~2.3
C.O.P	7.7~4.5	7.6~4.4
C.O.P in silence mode	7.7~5.2	7.6~5.1
Rated input power (kW)	1.6~0.22	2.1~0.25
Rated input current (A)	7.4~0.95	9.1~1.1
Power supply	230V/1 Ph/50Hz	
Advised water flux (m <sup>3</sup> /h)	4~6	5~7
Sound pressure 1m dB(A)	39.5~48.2	42.8~52.1
Sound pressure 10m dB(A)	19.5~28.2	22.8~32.1
Water pipe in-out Spec (mm)	50	
Net Dimension LxWxH (mm)	961x312x658	961x312x658
Net Weight (kg)	50	52

1. The values indicated are valid under ideal conditions: Pool covered with an isothermal cover, filtration system running at least 15 hours a day
2. Related parameters are subject to adjustment periodically for technical improvement without further notice. For details please refer to nameplate.◦

## > 1. Transportation

1.1. When storing or moving the heat pump, the heat pump should be at the upright position.

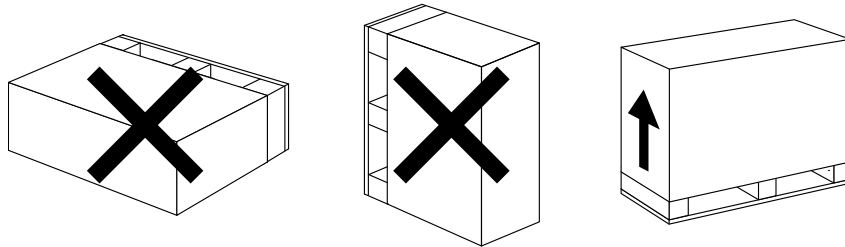

1.2. When moving the heat pump, do not lift the water union since the titanium heat exchanger inside the heat pump will be damaged.

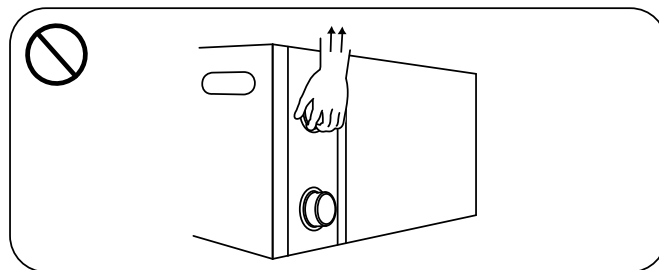

## > 2. Installation and maintenance

 The heat pump must be installed by a professional team. The users are not qualified to install by themselves, otherwise the heat pump might be damaged and risky for users' safety.

2.1. Notice before installation :

2.1.1. The inlet and outlet water unions can't bear the weight of soft pipes. The heat pump must be connected with hard pipes!

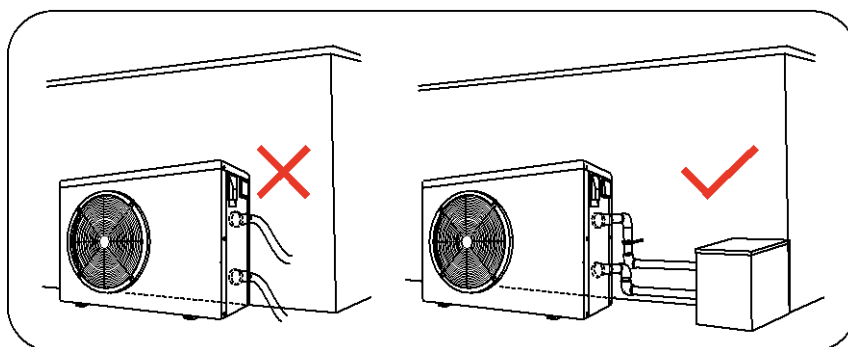

2.1.2. In order to guarantee the heating efficiency, the water pipe length should be  $\leq 10\text{m}$  between the pool and the heat pump.

## 2.2. Installation instruction

### 2.2.1. Location and size

 The heat pump should be installed in a place with good ventilation

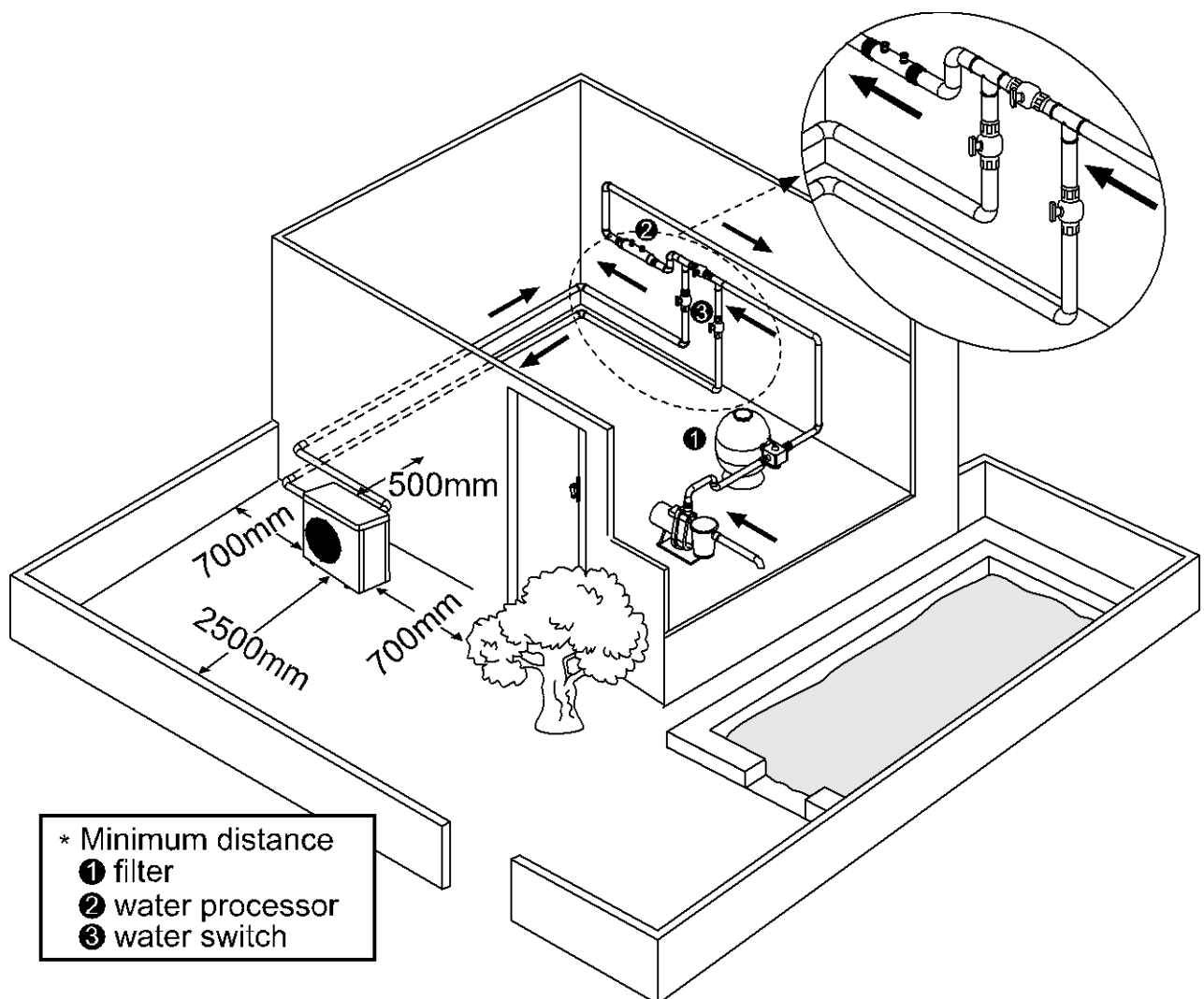

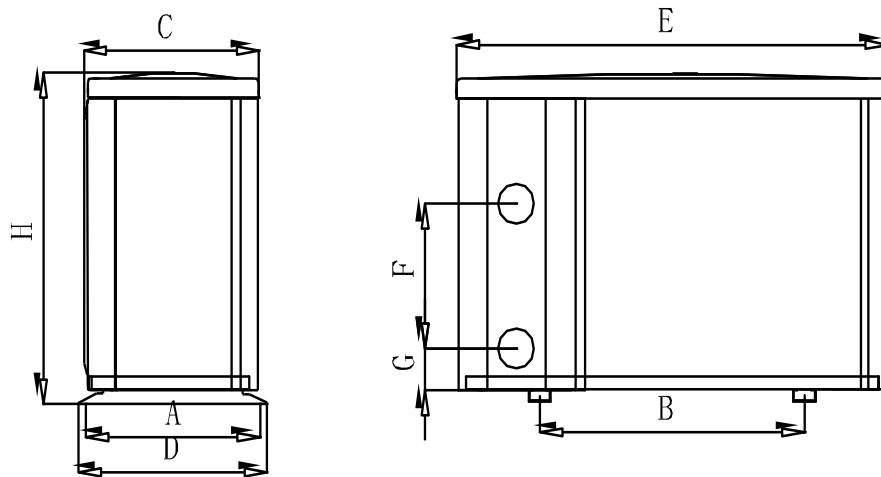

Size(mm) Model	A	B	C	D	E	F	G	H
<b>34-180139</b>	315	590	312	340	961	340	74	658
<b>34-180140</b>	315	590	312	340	961	340	74	658

※Above data is subject to modification without notice.

### 2.2.2. Heat pump installation.

- ① The frame must be fixed by bolts (M10) to concrete foundation or brackets. The concrete foundation must be solid; the bracket must be strong enough and anti-rust treated;
- ② The heat pump needs a water pump (Supplied by the user). The recommended pump specification-flux: refer to Technical Parameter, Max. lift  $\geq 10\text{m}$
- ③ When the heat pump is running, there will be condensation water discharged from the bottom, please pay attention to it. Please insert the drainage tube(accessory) into the hole and clip it well, then connect a pipe to drain off the condensation water.

### 2.2.3. Wiring & protecting devices and cable specification

- ① Connect to appropriate power supply, the voltage should comply with the rated voltage of the products.
- ② Well earth the heat pump.
- ③ Wiring must be connected by a professional technician according to the circuit diagram.
- ④ Set breaker or fuse according to the local code (leakage operating current  $\leq 30\text{mA}$ ).
- ⑤ The layout of power cable and signal cable should be orderly and not affecting each other.

**i** 1. Wiring diagram

**For power supply: 230V 50Hz**

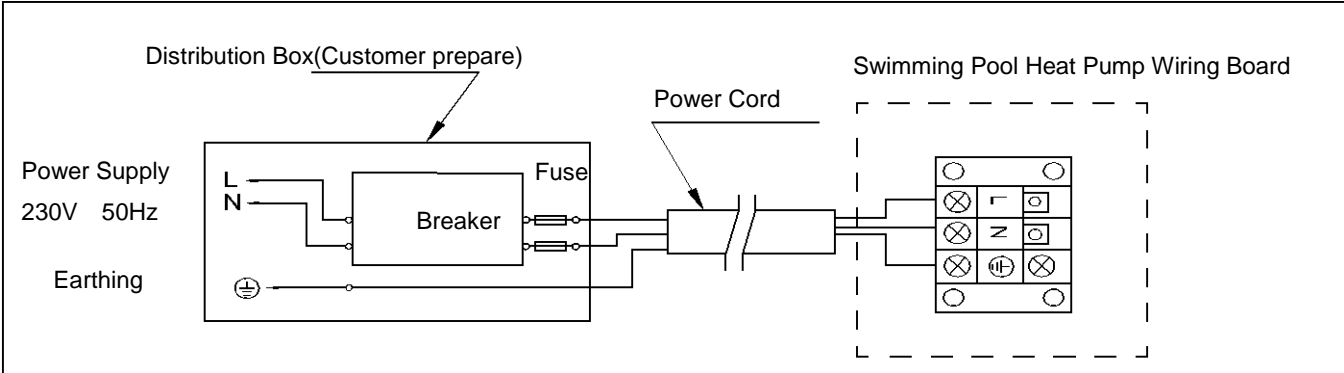

Note: For your safe use in winter, it's strongly recommended to equip heating priority function. For the detailed wiring diagram, please refer to Appendix 1.

**i** 2. Options for protecting devices and cable specification

MODEL		34-180139	34-180140
Breaker	Rated Current A	12	13
	Rated Residual Action Current mA	30	30
Fuse	A	12	13
Power Cord (mm <sup>2</sup> )		3×2.5	3×2.5
Signal cable (mm <sup>2</sup> )		3×0.5	3×0.5

NOTE: The above data is adapted to power cord ≤ 10m .If power cord is >10m, wire diameter must be increased. The signal cable can be extended to 50m at most.

## 2.3. Trial after installation

 Please check all the wirings carefully before turning on the heat pump.

### 2.3.1. Inspection before use

- ① Check installation of the whole heat pump and the pipe connections according to the pipe connecting drawing;
- ② Check the electric wiring according to the electrical wiring diagram and earthing connection;
- ③ Make sure that the main power is well connected;
- ④ Check if there is any obstacle in front of the air inlet and outlet of the heat pump

### 2.3.2. Trial

- ① The user is advised to start the water pump before the heat pump, and turn off the heat pump before the water pump for long life circle.
- ② The user should start the water pump, and check for any leakage of water; Power on and press the ON/OFF button of the heat pump, and set desired temperature in the thermostat.
- ③ In order to protect the heat pump, the heat pump is equipped with start delay function. When starting the heat pump, the fan will start to run in 3 minutes, in another 30 seconds, the compressor will start to run.
- ④ After pool heat pump starts up, check for any abnormal noise from the heat pump.
- ⑤ Check the temperature setting

## 2.4. Maintenance and winterizing

### 2.4.1 Maintenance

 The maintenance should be carried out once per year by qualified professional technician.

- ① Cut off power supply of the heat pump before cleaning, examination and repairing . Do not touch the electronic components until the LED indication lights on PCB turn off.
- ② Please clean the evaporator with household detergents or clean water, NEVER use gasoline, thinners or any similar fuel.
- ③ Check bolts, cables and connections regularly.

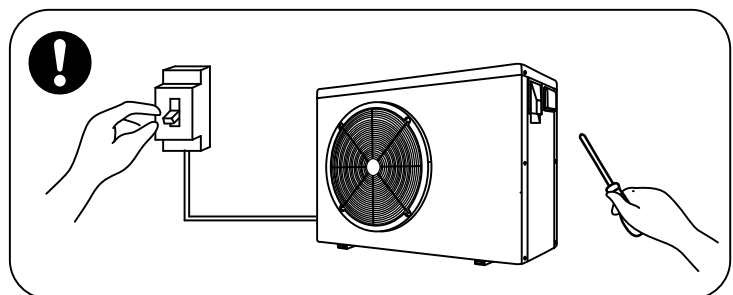

### 2.4.2 Winterizing

In winter season when you don't swim, please cut off power supply and drain water out of the heat pump. When using the heat pump under 0°C, make sure that the water pump is always running.

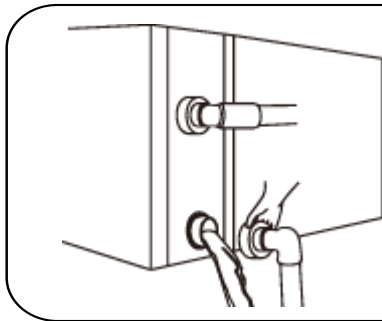

**⚠ Important:**

Unscrew the water union of inlet pipe to let the water flow out.

When the water in machine freezes in winter season, the titanium heat exchanger may be damaged.

## > 3 . Trouble shooting for common faults

Failure	Reason	Solution
<b>Heat pump doesn't run</b>	No power	Wait until the power recovers
	Power switch is off	Switch on the power
	Fuse burned	Check and change the fuse
	The breaker is off	Check and turn on the breaker
<b>Fan running but with insufficient heating</b>	evaporator blocked	Remove the obstacles
	Air outlet blocked	Remove the obstacles
	3 minutes start delay	Wait patiently
<b>Display normal, but no heating</b>	Set temp. too low	Set proper heating temp.
	3 minutes start delay	Wait patiently
If above solutions don't work, please contact your installer with detailed information and your model number. Don't try to repair it yourself.		

**ATTENTION! Please don't try to repair the heat pump by yourself to avoid any risk.**

#### > 4. Failure code

NO.	Display	Failure description
1	E1	High gas pressure protection
2	E2	Low gas pressure protection
3	E3	No water flow protection (not failure)
4	E4	3 phase sequence protection (only for three phase)
5	E5	Outdoor power supply abnormality protection
6	E6	Excessive temp. difference between inlet and outlet water(Insufficient water flow protection)
7	E7	Protection of low outlet water temperature
8	E8	Protection of high exhaust temperature
9	E9	Protection of compressor overheat ( reserved)
10	EA	Protection of evaporator overheat
11	EB	Ambient temperature too high/low protection
12	EC	Radiator high temperature protection
13	ED	Two-level antifreeze (not failure, only available when connecting to heating priority)
14	P0	Controller communication failure
15	P1	Water inlet temp sensor failure
16	P2	Water outlet temp sensor failure
17	P3	Gas exhaust temp sensor failure
18	P4	Evaporator I temp sensor failure
19	P5	Gas return temp sensor failure
20	P6	Heat exchanger temp sensor failure
21	P7	Ambient temp sensor failure
22	P8	Radiator temp sensor failure
23	P9	Current sensor failure
24	PA	Restart memory failure
25	F1	Compressor drive module failure
26	F2	PFC module failure
27	F3	Compressor start failure
28	F4	Compressor running failure
29	F5	Compressor module over current protection
30	F6	Compressor module overheat protection
31	F7	Current protection
32	F8	Radiator overheat protection
33	Fb	Capacitor No-power protection



Appendix 1: Heating priority wiring diagram (Optional)

For water pump: Voltage 230V, Capacity ≤500W

For water pump: Voltage 230V, Capacity >500W

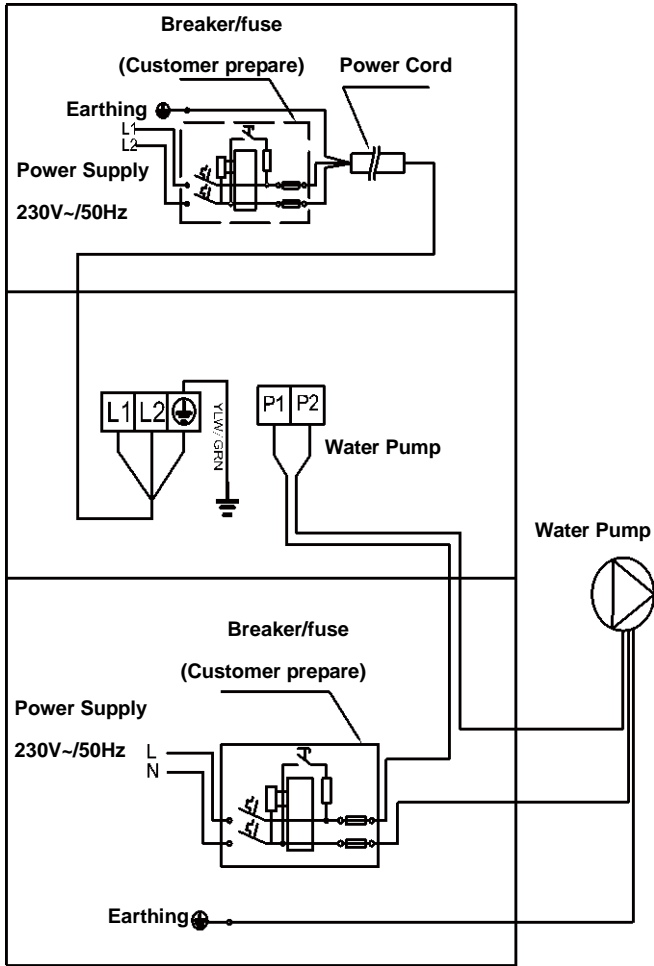
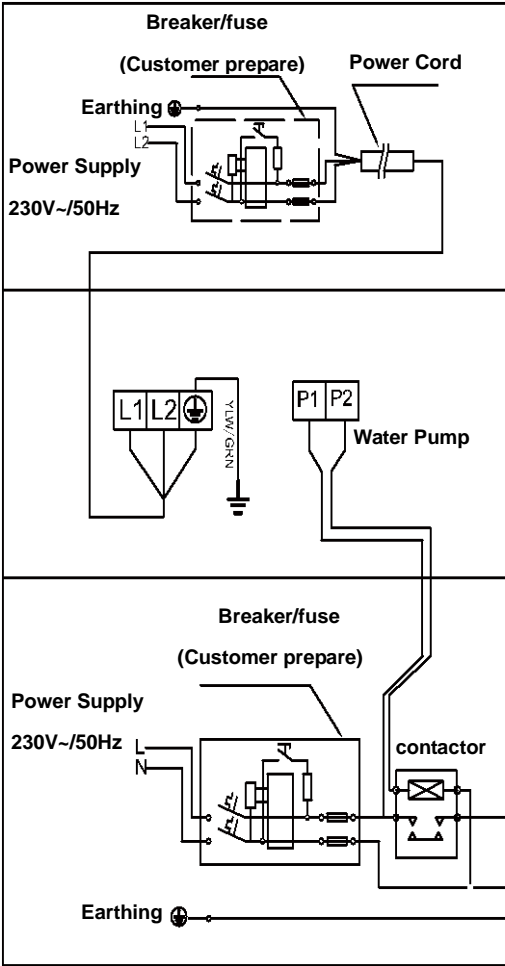

For water pump: Voltage 400V

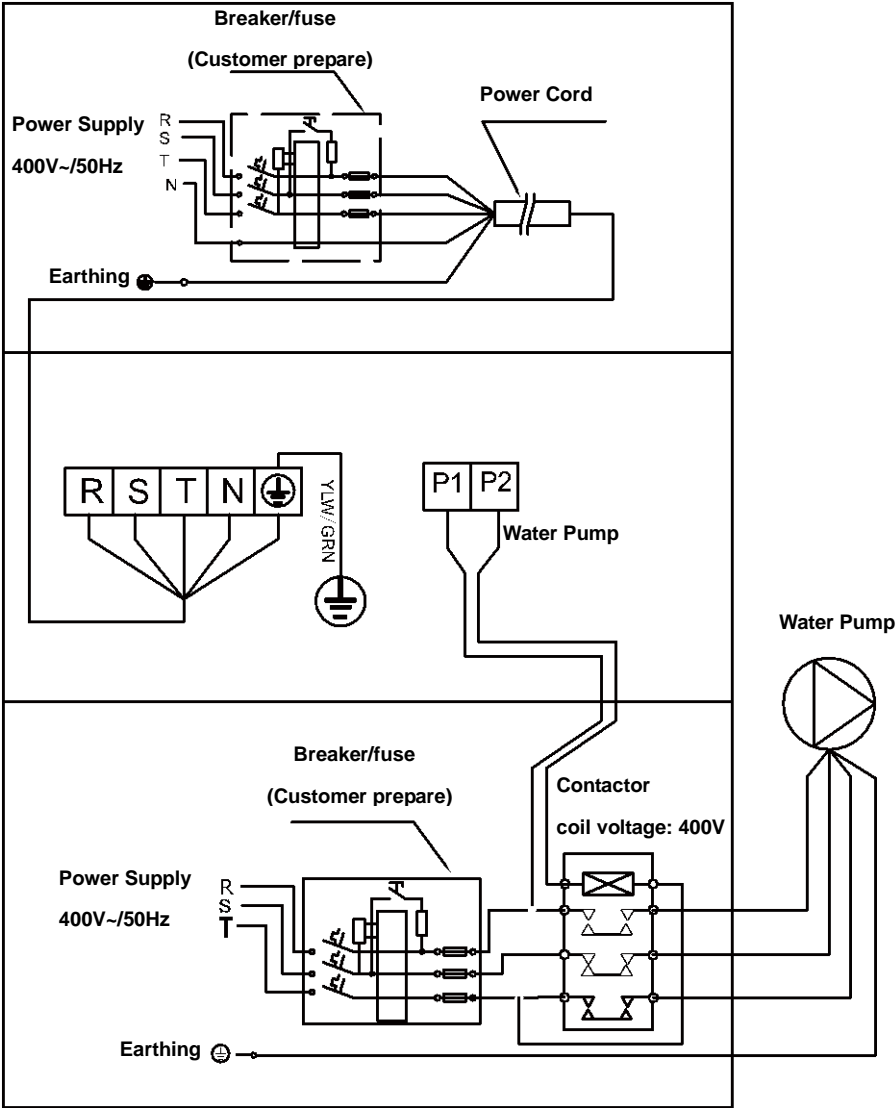

Parallel connection with filtration clock

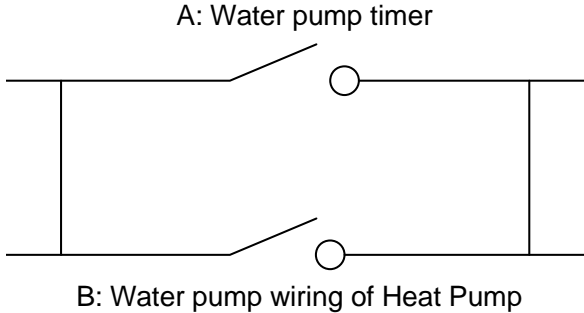

Note: The installer should connect A parallel with B (as above picture). To start the water pump, condition A or B is connected. To stop the water pump, both A and B should be disconnected.

Note:

**welldana**<sup>®</sup>  
